



CPP & IPP Automation Using SYNC 2100 And SYNC 3000

Application Note

Application Description

As per grid code guidelines for open access, it is mandatory for Independent Power Producers (IPPs) and Captive Power Producers (CPPs) to comply specified SCADA compatibility in the transmission network Load Dispatch Center (LDC) system where their feeders are inter-connected. Local SCADA HMI communication needs to be based on IEC61850 standard. Generation station usually has FO link to LDC, if not available Cellular/RF wireless technologies can be adopted to transfer data.

CPPs and IPP generate power at 6.6kV and hence a generated power is connected to grid by stepping up the voltage to 132kV. Sample SLDs is provided below for reference:

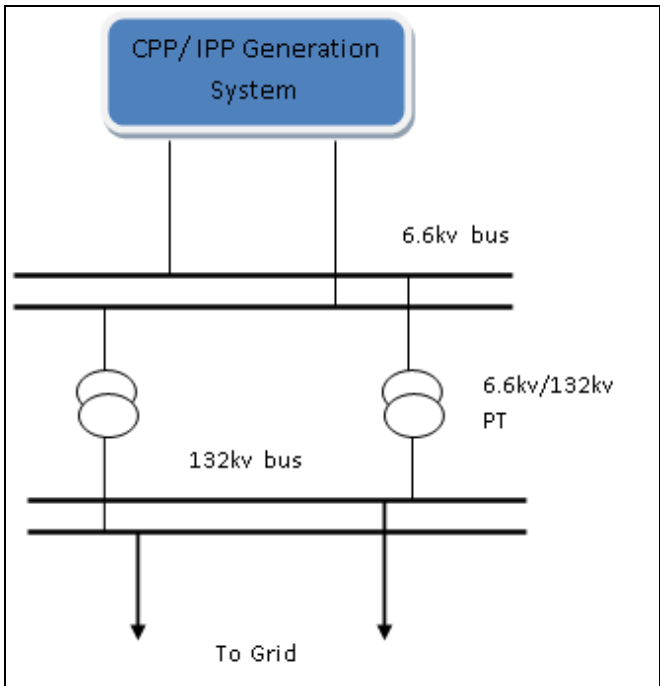

Figure 1: Sample SLD

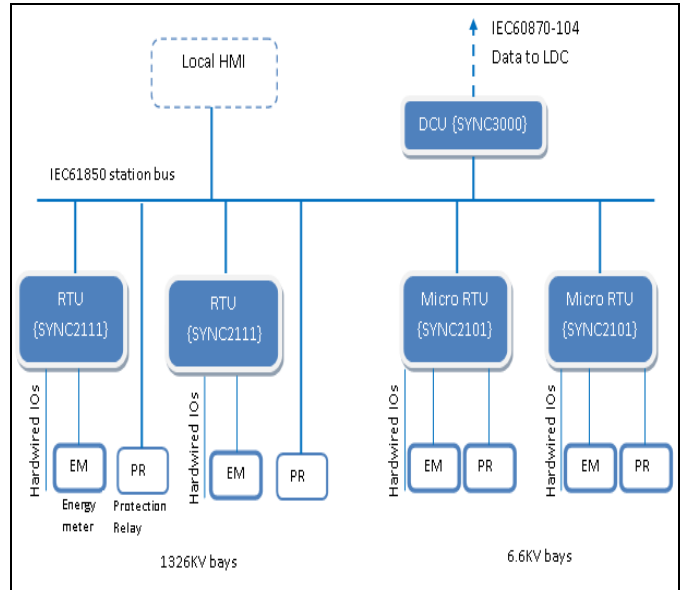

Figure 2: Application Solution

Data acquisition equipments shall be provided to acquire data from the CPP substation bays for transmitting to the LDC in addition to displaying locally. Local SCADA/HMI system shall be provided for monitoring of 132 kV bus, 6.6 kV buses and exchange of critical data with LDC in real time. The entire communication is based on open IEC standards to ensure future scalability and also to make the system vendor independent.

The solution is designed in a decentralized architecture to optimize communication, cabling and to achieve better management of data. Data acquisition units are categorically mapped to different functional points like Grid side where data is critical for LDC, 132kV switch yard with 132/6.6 kV transformers and 6.6 KV bus where generation units and plant loads are connected.

HV Feeder monitoring and data exchange with LDC

Grid breaker status and energy export data at grid interconnection point are critical information to State load dispatch centers. RTU having gateway capabilities shall be installed at the 132 kV grid feeders to acquire data from the feeder. The RTU shall be of modular architecture with I/O and communication capabilities. Status signals from switch gears shall be hardwired to the Input modules. RTU communicates with energy meter on

Application Solution

SCADA and LDC data reporting system comprises of RTU (Remote Terminal Unit), SCADA/HMI software, Communication network and DCU (Data Concentrator Unit). Diagram shown below depicts the solution architecture.

Modbus and protection relays directly communicate with SCADA/DCU on IEC-61850. The RTU shall communicate with LDC on IEC-61870-5-104 protocol via the dedicated optical link.

The optical link connects the CPP/IPP to the nearest grid substation. Data Concentrator Unit (DCU) shall be provided at the grid substation to establish communication with the RTU/IED at the CPP/IPP and interface to LDC network or SAS or station DCU at the grid substation. DCU shall be capable of communicating on IEC 60870-5-104, IEC 60870-5-101 and IEC 61850.

HV Transformer Monitoring

HV transformers of 132/6.6kV shall be monitored for their operational parameters by an RTU. Monitoring critical transformer parameters gives performance indication and provides an early view of equipment maintenance issues. RTU shall have hardwired signal interface for status and analog signals and also communication interface for IED communication. The RTU shall have IEC 61850 client and server for communication with IED and local SCADA/HMI respectively. Serial communication interfaces also shall be available to communicate with IEDs on IEC60870-5-103 and Modbus.

Monitoring of 6.6 kV load feeders and generator feeder

At 6.6 KV level feeder data are acquired by the micro/mini RTUs placed in respective cubicles. Micro/mini RTUs shall have inbuilt digital input and o/p interfaces for the data acquisition. In addition to I/O interface each micro/mini RTU shall have RS-485 and Ethernet port for upstream as well as downstream communications on IEC-61850, IEC 60870-5-103, Modbus protocols.

Features

- High end security over VPN and CIP enabled devices
- Transparent channel connectivity to the end devices for parameterization and disturbance upload

Products Used

Products used for CPP/IPP Automation are

- SYNC 3000 are station DCU
- SYNC 2111 as RTU for HV feeders
- SYN 2101 as RTU for 6.6kV feeders

Advantages

- Multi master communication capability
- Time synchronization is done on SNTP protocol
- Modular and expandable for future expansion
- Secured IE62351-3/ SSL VPN based security for LDC communication
- NERC/CIP Compliant DCU as a peripheral communication access point